

NOTES: UNLESS OTHERWISE SPECIFIED

1. MATERIALS AND COMPONENTS ARE RoHS/REACH COMPLIANT.
2. CONNECTORS MEET THE REQUIREMENTS OF ANSI/TIA 568-C.2.
3. CABLE ASSEMBLIES ARE MANUFACTURED TO C ENTERPRISES STANDARDS.
4. STANDARDS AND SPECIFICATIONS AVAILABLE UPON REQUEST.
5. TESTED FOR CONTINUITY, SHORTS, WIRE MAPPING AND OVERALL INTEGRITY.
6. ADHESIVE HEAT SHRINK FOR STRAIN RELIEF.

REV	ECR	DESCRIPTION	BY	DATE	CHECKED
A	-	INITIAL RELEASE	M. K	01/23/2019	A.J

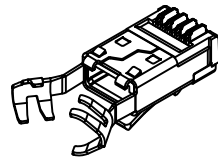
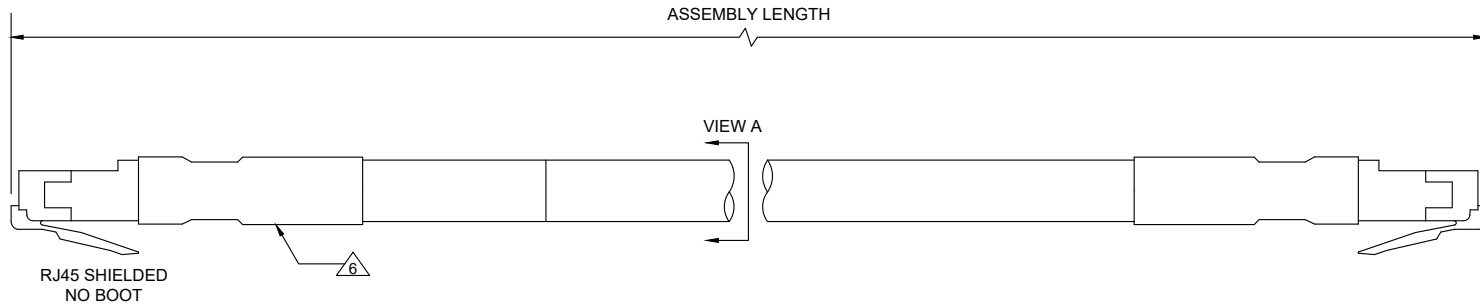

CONNECTOR DEPICTION
NOT TO SCALE

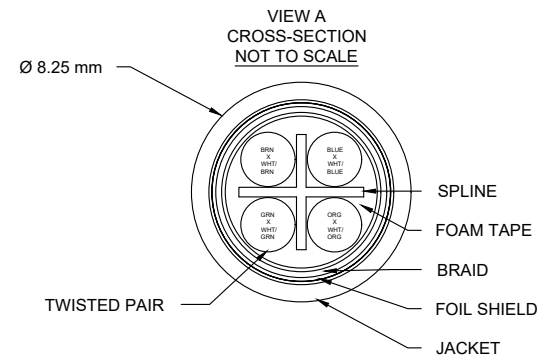

CABLE PROPERTIES		
TEMPERATURE RATING RANGE	[-40°C, 75°C]	
CABLE SWEEP FREQUENCY	500 MHz	
VOLTAGE RATING MAX	600 V	
JACKET MATERIAL	THERMOPLASTIC ELASTOMER	
JACKET RESISTANCE	SUNLIGHT RESISTANT WELD SPLATTER RESISTANT OIL RESISTANT	
BILL OF MATERIALS		
ITEM	QUANTITY	COMPONENT
3	AR	ADHESIVE HEAT SHRINK; BLACK
2	AR	STP 4PR 24 AWG SOLID W/SPLINE CAT6/6A CMX INDUSTRIAL SHIELDED OSP; BLACK
1	2	RJ45 CAT 6A SHIELDED CONNECTOR W/LOAD BAR; NO BOOTS

WIRING CONFIGURATION 568B STRAIGHT		
P1	COLOR CODE	P2
1	WHITE/ORANGE	1
2	ORANGE/WHITE	2
3	WHITE/GREEN	3
4	BLUE/WHITE	4
5	WHITE/BLUE	5
6	GREEN/WHITE	6
7	WHITE/BROWN	7
8	BROWN/WHITE	8
SHELL GROUND	SHIELD	SHELL GROUND

DESCRIPTION: RJ45 SHIELDED TO RJ45 SHIELDED, CAT6/6A SHIELDED INDUSTRIAL CMX COPPER PATCH CORD, BLACK, NO BOOT.		
DRAWN BY:	M. KHANFIR	01/23/2019
APVD BY:	A. JENSEN	01/23/2019
DIMENSIONS: METRIC [IMPERIAL]		TITLE: CAT 6/6A HI-FLEX INDUSTRIAL PATCH CORD
PROPRIETARY AND CONFIDENTIAL		SIZE: A
THIS DOCUMENT CONTAINS PROPRIETARY INFORMATION OF C ENTERPRISES. NOT TO BE USED, COPIED, OR DISCLOSED WITHOUT WRITTEN PERMISSION. ALL RIGHTS RESERVED.		DWG. NO.: CUSTOM
SCALE: NOT TO SCALE		REV: A
SHEET 1 OF 1		



C ENTERPRISES
2445 CADES WAY
VISTA CA 92081
760-599-5111